

# GN 431

Wing knobs

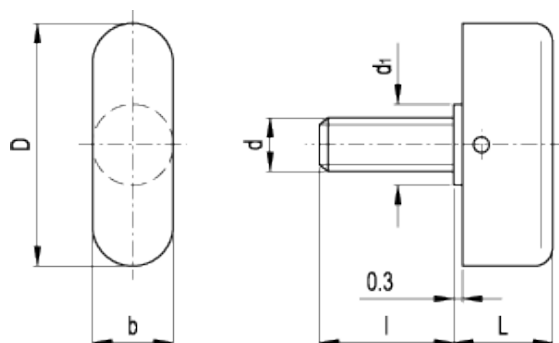

INOX  
Stainless Steel



## technical informations

### Material

AISI 316L sintered stainless steel, sandblasted matte finish.

### Assembly

AISI 304 stainless steel threaded pin, screwed and set in the body with a lock pin.

### Features and applications

These wing knobs allow high tightening torque values.

AISI 304 and AISI 316L stainless steel, thanks to their high resistance to corrosion, allow the application of these wing knobs on machines and equipment in those sectors where laws or particular hygienic, climatic and environmental factors make it mandatory to use corrosion resistant materials.

| Standard Elements | Main dimensions |    |    |                | Threaded stud |                      | Weight |
|-------------------|-----------------|----|----|----------------|---------------|----------------------|--------|
| Description       | D               | L  | b  | d <sub>1</sub> | d             | l <sub>+0.5 -1</sub> | g      |
| GN 431-25-M6-16   | 25              | 10 | 8  | 8              | M6            | 16                   | 15     |
| GN 431-25-M6-20   | 25              | 10 | 8  | 8              | M6            | 20                   | 16     |
| GN 431-25-M6-25   | 25              | 10 | 8  | 8              | M6            | 25                   | 17     |
| GN 431-30-M6-16   | 30              | 12 | 10 | 10             | M6            | 16                   | 25     |

|                  |    |      |    |    |     |    |    |
|------------------|----|------|----|----|-----|----|----|
| GN 431-30-M6-20  | 30 | 12   | 10 | 10 | M6  | 20 | 25 |
| GN 431-30-M6-25  | 30 | 12   | 10 | 10 | M6  | 25 | 25 |
| GN 431-30-M8-16  | 30 | 12   | 10 | 10 | M8  | 16 | 26 |
| GN 431-30-M8-20  | 30 | 12   | 10 | 10 | M8  | 20 | 28 |
| GN 431-30-M8-25  | 30 | 12   | 10 | 10 | M8  | 25 | 30 |
| GN 431-30-M8-32  | 30 | 12   | 10 | 10 | M8  | 32 | 32 |
| GN 431-36-M8-16  | 36 | 14.5 | 12 | 12 | M8  | 16 | 44 |
| GN 431-36-M8-20  | 36 | 14.5 | 12 | 12 | M8  | 20 | 45 |
| GN 431-36-M8-25  | 36 | 14.5 | 12 | 12 | M8  | 25 | 50 |
| GN 431-36-M8-32  | 36 | 14.5 | 12 | 12 | M8  | 32 | 49 |
| GN 431-36-M10-20 | 36 | 14.5 | 12 | 12 | M10 | 20 | 48 |
| GN 431-36-M10-30 | 36 | 14.5 | 12 | 12 | M10 | 30 | 53 |
| GN 431-36-M10-40 | 36 | 14.5 | 12 | 12 | M10 | 40 | 55 |



ELESA and GANTER models all rights reserved in accordance with the law. Always mention the source when reproducing our drawings.

STANDARD MACHINE ELEMENTS WORLDWIDE